

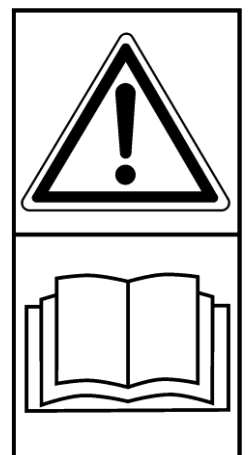

# Instructions for use and maintenance

## Sandspreader SP250-400-600-800- 1000-1600-2700



**Note!**  
Read instructions before use



**TREJON FÖRSÄLJNINGS AB**  
Företagsvägen 9  
SE-911 35 VÄNNÄSBY  
SWEDEN  
Tel: + 46 (0)935 39 900  
Webb: trejon.se





## ■ TABLE OF CONTENTS

<b>1</b>	<b>General Information .....</b>	<b>7</b>
1.1	Description.....	7
1.2	Technical specification .....	7
<b>2</b>	<b>Safety instructions .....</b>	<b>8</b>
2.1	Safety directions .....	8
2.2	Explanation of the symbols.....	10
<b>3</b>	<b>Using the equipment .....</b>	<b>12</b>
3.1	Before starting up .....	12
3.2	Adjustment of spreading quantity .....	13
3.3	Operating the sand spreader.....	15
<b>4</b>	<b>Service and maintenance .....</b>	<b>16</b>
4.1	Lubrication points .....	16
4.2	Before you start a new season .....	16
4.3	After the end of the season .....	16
<b>5</b>	<b>Troubleshooting .....</b>	<b>17</b>
<b>6</b>	<b>Options.....</b>	<b>18</b>
6.1	Assembly of Self-loading equipment (optional) .....	18
6.2	Curtain cover .....	19
6.3	Safety lattice .....	21
<b>7</b>	<b>Spare parts.....</b>	<b>22</b>
	<b>EC-Certificate of Conformity .....</b>	<b>24</b>

# SAFETY SYMBOLS

Note! This warning symbol is used throughout this instruction manual to call attention to safety precautions that you, your employees or any other people that may come near the implement must read and understand. Failure to follow these instructions may result in serious injury or even death.

This symbol means:



**WARNING!**  
**CAUTION!**  
**YOUR SAFETY IS**  
**ENDANGERED!**

## A word of advice

Pay special attention to the words **WARNING!**, **CAUTION!** and **NOTE!** in the safety instructions. The words have been chosen from of the following:



**WARNING!** This safety sign is used to identify potential hazards that can lead to serious injury or even death. These hazards include situations that may occur when the safety equipment and/or the safety shields are removed. Signal words can also be used to alert about dangerous use.



**CAUTION!** Failure to observe this warning sign could result in light personal injuries. The sign is also used to indicate that the disregarding of these instructions may cause damage to the implement.

Dear Customer,

You have made a good choice. We congratulate you to your selection of an OPTIMAL-product that offers quality and performance with reliable service.

By reading the manual and following its recommendations you will ensure the long and effective use of the equipment.

We have produced this manual for you to get a good understanding of the functioning of the equipment and what safety and maintenance instructions to follow when working with it. If any question should arise when using the equipment or when reading this manual, you are welcome to contact us for further information.

TREJON AB  
Företagsvägen 9  
SE-911 35 Vännäsby  
Sweden

Tel: + 46 (0)935 39 900  
Email: [info@trejon.se](mailto:info@trejon.se)  
Website: [www.trejon.se](http://www.trejon.se)

Honoured retailer,

In order for the guarantee to be valid and to fulfil all legal requirements, we ask you to fill out the guarantee form together with the customer and register at **trejon.se**

The guarantee is valid from the day the equipment is handed over to the customer.

Delivery checklist:



Check for damages caused in transporting. Inform the transporting company.	
Check that all packing material has been taken away. Dispose packing material in an environmentally friendly way	
Check that the machine is lubricated, see section "Service and maintenance".	
Check that chain has right tension, see section "Service and maintenance".	
Check that all screws are properly tightened, see section "Service and maintenance".	
Make a function test	
Having gone through and explained to the customer, with the help of the manual, the startup, use and maintenance of the equipment and it's accessories.	
Fill out the guarantee form with the customer and register at trejon.se	
Instruction manual given to the customer.	

Enter the serialnumber of the equipment to the right.	S/N:
---	------

## 1 General Information

Thank you for choosing our Optimal sand-spreader. We have worked hard to manufacture a strong and reliable sand-spreader that will last for many years. As the machine's service life does not depend solely on us but also on you we have prepared the se guidelines that describe the proper use and maintenance of the machine. Please read the whole manual carefully before operating the machine. If you want to order spare parts or need service, please contact the company where you bought the machine. When submitting the order for the spare parts, specify the model, type and serial number from the name plate on the chassis of the machine.

### 1.1 Description

The OPTIMAL sand-spreader is a simple and easy-to-operate machine for spreading sand (0-4 mm), chip stone (2-8 mm) and salt. It is recommended that the spreading material is sifted into correct fractions. The sand-spreader is installed on a front loader or to a tractor's hitch linkage with TREJON connection frame.

The spreader is driven by the tractor's hydraulics and the sand-spreading operation is regulated with a hydraulic flow valve. The flow of material spread can also be adjusted with a rubber flap that is pressed against the spreading roller.

It is easy to fill the spreader; the filling principle is the same as a loader's bucket. To facilitate the filling when the spreader is mounted on the 3-p hitch linkage a special "self-loading" kit can be supplied as an option.

### 1.2 Technical specification

Model	SP250	SP400	SP600	SP800	SP1000	SP1600	SP2700
Spreading width, cm	120	140	160	160	200	220	220
Capacity, liters	250	400	600	800	1000	1600	2700
Dimensions, WxH, ~cm	135x63	164x88	184x88	184x103	224x103	240x123	262x130
Weight, kg	125	280	325	350	390	750	1000 (incl.cone.)
Oil flow, l/min	12-70*	25-70*	25-70*	25-70*	25-70*	40-120	40-120
Cover plates	N/A	2x40m	2x40m	2x40m	2x40m	2x60cm	2x60cm
Connection to tractor	3-p / Flexitrac	Optional connection -frame	Optional connection-frame	Optional connection-frame	Optional connection-frame	Optional connection-frame	Stora BM

Due to continuous product development, any data is subject to change without prior notice.

**\* If the oil flow capacity exceeds 70 l/min, more powerful flow regulator and hoses must be used (available as additional equipment, Part.no. SP-1000-30). This is of utmost importance when the spreader is put on a wheel loader.**

## 2 Safety instructions



### 2.1 Safety directions

Read this user manual and the safety directions carefully before using the equipment for the first time.

Erroneous or negligent use of this equipment can lead to serious accidents. This equipment is only for outdoor use.

- Read and understand the contents of this manual on the use of this equipment.
- Learn and practice the controls and the way the equipment works before using it.
- Let the machine work by itself; do not try to help using your fingers or hands.
- Check, adjust and maintain the equipment according to this manual.
- To maintain and adjust this equipment, it must be placed on a firm, level surface.
- Ensure that nobody is inside the working area of the equipment.
- Whenever you clean or check the equipment, you must stop the engine of the tractor. The tractor must be immobilized with the parking brake, and the spreader must be lowered to the ground. Ensure that all moving parts have stopped.
- Take care that arms or legs do not touch the moving parts of the equipment.
- Make sure that all protective parts are properly in place and that they are in good condition.
- Keep children and other people out from the machines working area.
- The hydraulic hoses and tubes contain oil under high pressure. Do not touch hoses and hydraulic components if there is pressure in the system. Oil under high pressure can penetrate the skin and cause serious damage.
- Daily check the hydraulic hoses of the machine with regards to damages and oil leakage. Worn and leaking hoses must immediately be replaced with new ones, which fulfil the manufacturer's technical demands.
- When changing tractor, please check the hoses length. Too long or too short hoses can be damaged during use.
- When working in the dark hours, make sure there is sufficient lighting in the working area.
- The engine of the tractor must be switched off and the parking brake applied when cleaning, adjusting, maintaining and repairing the equipment.
- The equipment should only be used if all the original protective parts installed by the manufacturer are properly fitted and if no unauthorized persons, in particular children are within the working area.

- When connecting, never stand between the tractor and the equipment as long as the tractor is moving.
- Do not use the equipment if it is vibrating or shaking. Stop and investigate the cause. Change any damaged parts.
- Be careful when lifting or lowering the equipment.
- If the equipment has been raised for cleaning, maintenance, inspection or repairs, it is imperative that you prevent it from sinking or falling down. Place supports under the equipment to prevent it from sinking or falling down.
- To ensure that the towing vehicle has sufficient steering and braking, at least 20% of the weight of the towing vehicle must rest on the front/rear axle. If this is not the case, add weights to achieve the correct ratio. See the manual for the tractor.

Attention also has to be paid to the following:

- Adapt your driving to the prevailing terrain and ground conditions.
- You may not transport people on the equipment.
- Unauthorized persons, particularly children, may not stay in the proximity of equipment that is working or being repaired.
- Persons under the influence of alcohol or drugs are prohibited to work with the equipment.
- Persons without relevant driving licence may not use the equipment.
- It is forbidden to work with this equipment if the protections for the moving parts or axles are missing.
- It is forbidden to adjust the equipment or to remove material from the agitator or spreading roller while the tractor engine is running.
- Be careful when working on uneven ground, reduce speed.
- Clean the equipment carefully before you repair it or put it away.
- Protect bearings, hydraulic system and electronic components before any welding is done.
- Ensure that nobody is inside the working area of the equipment.

Use only original spare parts for the equipment.

If you have any questions about the equipment or how it works, contact your retailer or TREJON AB

## 2.2 Explanation of the symbols

The warning symbol must always be recognizable. If the warning symbols are missing from your equipment or if they are damaged, replace them at once.

The symbol to the right shows:



Warning!

Read and follow the manual and the safety instructions before using the equipment. Pass on all safety instructions to other users of the equipment.



Warning!

Do not touch moving parts. Do not move about near the rotating parts when the equipment is operating.



Warning!

Crushing hazard! When connecting, never stand between the tractor and the equipment as long as the tractor is moving. The tractor must be immobilized with the parking brake whenever the operator leaves the cabin.







Warning!

Crushing hazard!



The CE symbol mounted by the manufacturer confirms that the equipment altogether meets all requirements concerning machinery directives and other corresponding EG directives.

The serial number and model is stamped on the identifying plate (see the picture).

		TREJON AB Företagsvägen 9 SE- 911 35 VÄNNÄSBY SWEDEN <a href="http://www.trejon.se">www.trejon.se</a>			
Model	<input type="text"/>	Model Year	<input type="text" value="20"/>		
Serial No.	<input type="text"/>	Prod. Year	<input type="text" value="20"/>		
Weight	<input type="text"/>	kg	Total Weight	<input type="text"/>	kg

### 3 Using the equipment

#### 3.1 Before starting up

- Lubricate the machine before you start it. There are four lubrication nipples on the machine (one on each bearing housing). Also oil the roller chain
- Check roller chain tension, tension if necessary.
- Ensure that the guard that protects the sprocket is in place; please also check all the nuts and bolts are securely tightened.
- Connect the machine to the tractor and lock the connections
- Connect the machine's hydraulic hoses to the tractor; using the tractor's double acting outlets or single acting hydraulic connection with free flow return to tank. If the tractor has a "closed centre" hydraulic system as may be the case with some John Deere models earlier than 6000 series, the machine's hydraulic system needs to be modified as shown in the figure below. If necessary, Trejon can do this before delivery (for an additional fee). The return hose is supplied with a check-valve which allows the flow only to going one direction, this avoids damage which may occur if the pressure and return hoses are accidentally confused (if this is the cases, the spreading roller won't move).
- Check the rolling direction of the spreading roller after the hydraulic hoses have been connected. See also that the hydraulic hoses are not trapped during driving of the machine.

Standard "Open" hydraulic system

"Closed centre" hydraulic system

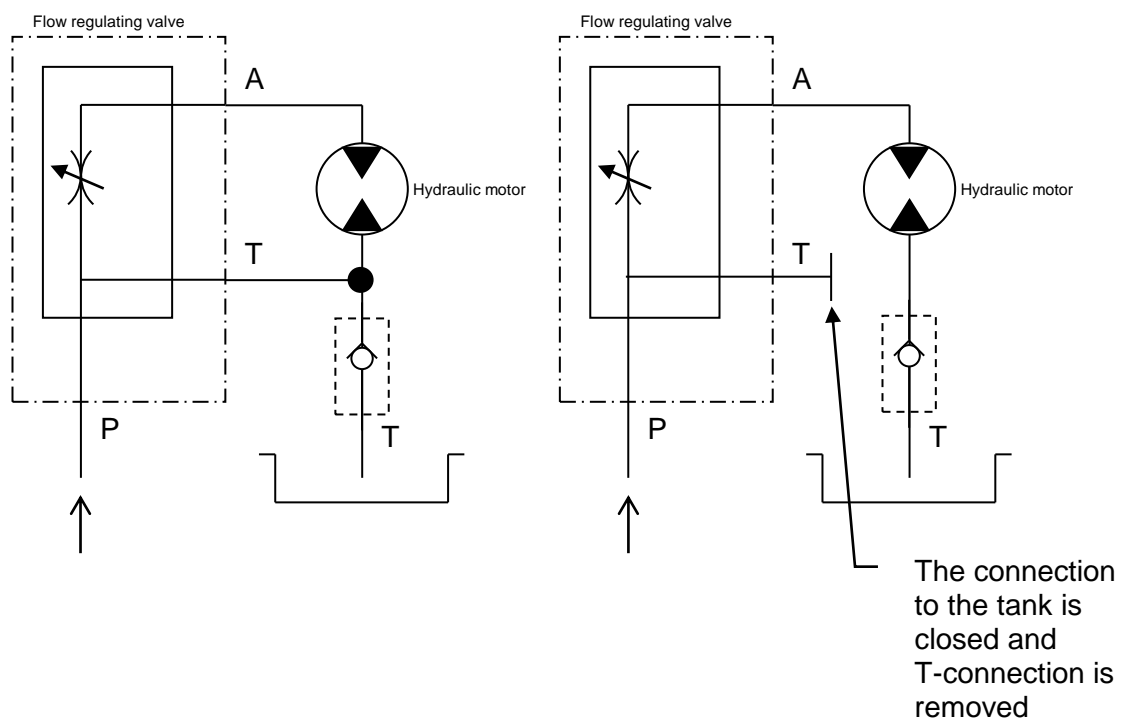

### 3.2 Adjustment of spreading quantity

The speed of the spreading roller, the pressure of the rubber flap against the roller and the position of the cover plates can regulate the quantity of spreading material.

#### Spreading roller speed

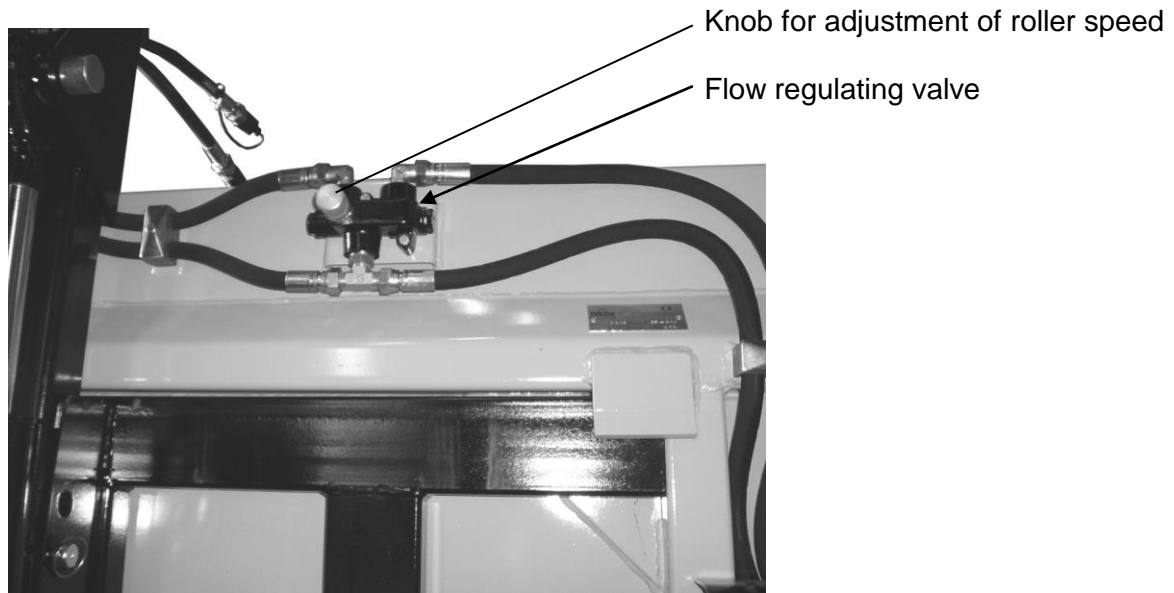

By turning the knob on the flow regulating valve can the speed of the spreading roller be adjusted.

#### Road depending steering ELSK (Option)

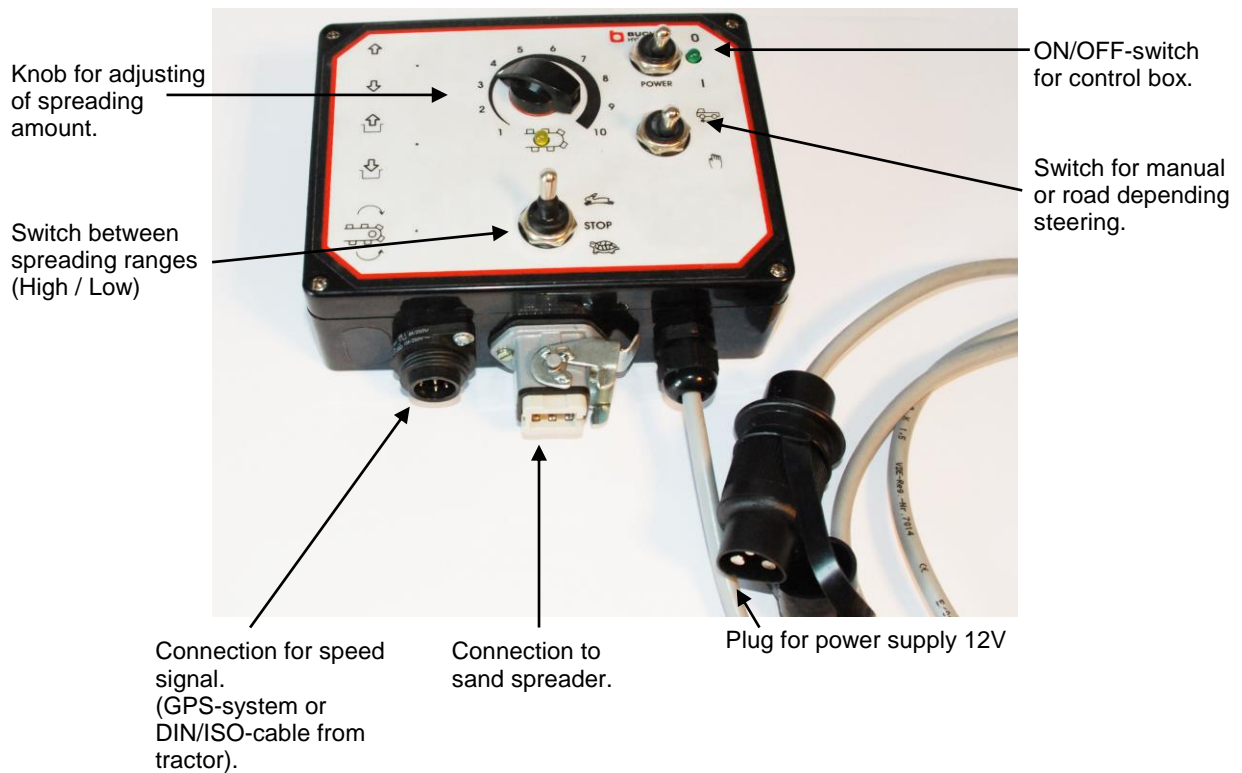

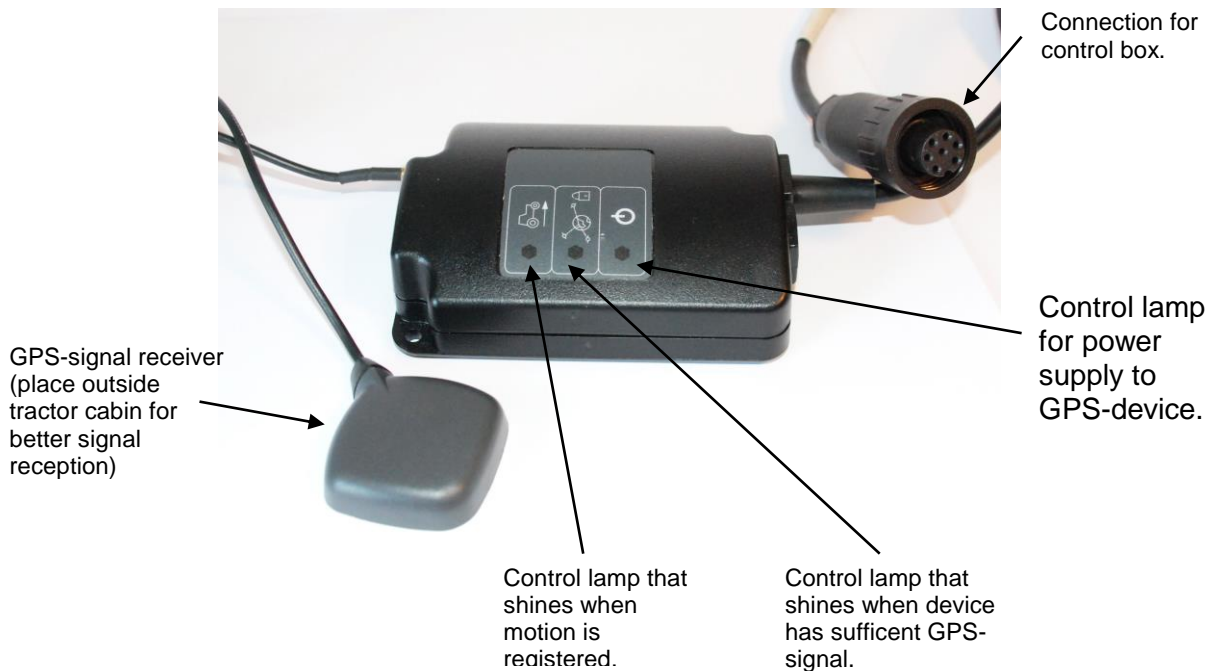

GPS-device 90-02371 (only for 12V power supply)

Sand spreaders SP400, SP600, SP800, SP1000, SP1600 and SP2700 can be equipped with a road depending steering system which compensate spreading amount after changes in driving speed. Steering system demands a speed signal, which can be received from either OPTIMAL GPS-system (item number 90-02371) or by an ISO/DIN –cable at tractors equipped with an outlet. Note that road depending steering just can be used together with 12V electrical system.

At practical use, the sand spreader vehicle is driven in working speed while spreading amount is adjusted with adjusting knob at control box. When right adjustment is found the road depending system ELSK will compensate spreading amount after driving speed.

**When using the road depending steering the machine demands a special valve.**



**NOTE!**

**The control box is adjusted from factory, and is NOT allowed to be opened by the user. At any questions about its function, the control box has to be handed over to your TREJON dealer.**

## Spring loaded rubber flap

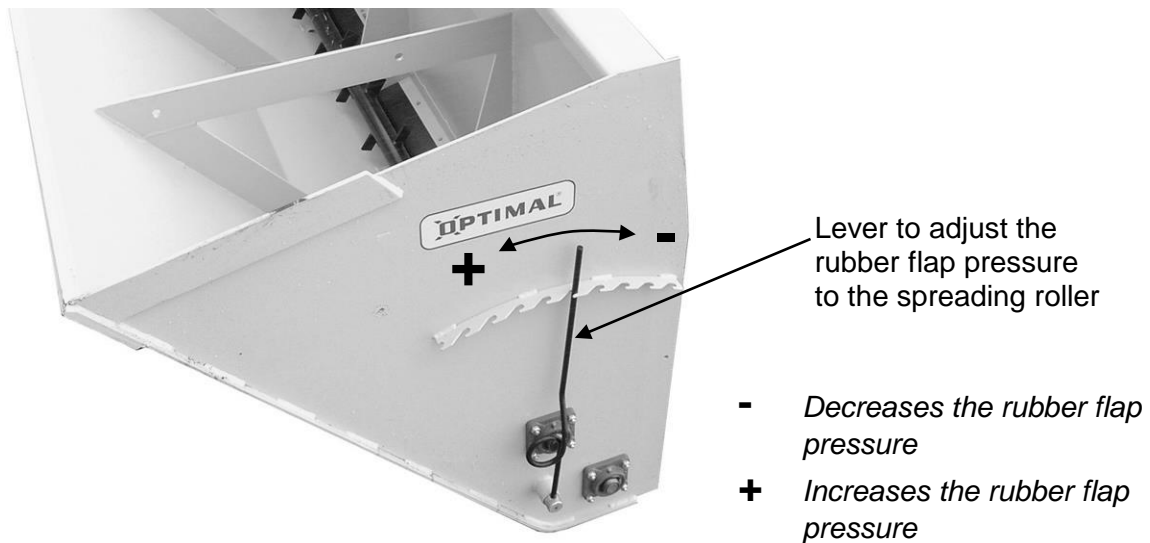

The pressure of spring-loaded plate against the rubber flap is to be adjusted so as to achieve the desired spreading density by the weakest possible pressure against the spreading roller. Therefore you decrease the wear of the rubber flap. If the rubber flap is worn it can be reversed.



**Ease the tension of the rubber flap when the machine is not in operation.**

### Track spreading (not possible with SP250)

Insert plates are placed in wished position inside spreader (above spreading roller) if track spreading is needed.

## 3.3 Operating the sand spreader

Fill the sand-spreader as you would an ordinary bucket loader, for instructions regarding self-loading 3-p hitch mounted bucket, please see part 6,2. The material used must not contain stones or frozen pieces. Adjust the machine according to the work to be done. During working, the sand-spreader must be in a risen, "sloped" position. Keep the rpm of the tractor engine steady as you drive the tractor, observing that the hydraulic pressure and flow values are constant during spreading.

The machine must be cleaned and oiled each time after you have finished working. Ease the tension of the rubber flap when the machine is not in operation. This will help to spare the rubber flap and provides better contact surface.

### After use

Empty and clean the spreader after driving, and if necessary, rust-proof exposed parts, eg. bearings.

### Emptying the spreader container

The material in the spreader can be emptied by putting the lever at the side of the bucket towards "-" until a slot appears between the rubber flap and the roller (the lever has to be put outside the toothed scale). The emptying of the bucket is more efficient if the spreading roller is rotating. A front loader mounted bucket is emptied thru tipping.

**Warning!**

At any time when performing repairs and maintenance, the engine must be switched off. Withdraw the ignition key from the switch.

## 4 Service and maintenance

**Warning!**

At any time when performing repairs and maintenance, the engine must be switched off. Withdraw the ignition key from the switch.

### 4.1 Lubrication points

Position	Interval	Type	Amount
Exposed details	If necessary	Rustproof with eg. oil film or wax.	
Spreading roller	40 h	Grease	2 pieces
Mixing roller	40 h	Grease	2 pieces
Chain transfer	40 h	Rub the oil or grease in, using a brush.	
Chain tensing pulley	40 h	Check the tension of the chain. You must be able to press the chain down 7 mm. The transfer system must work smoothly, without creaking.	

### 4.2 Before you start a new season

Please perform all the necessary operations and checks described above. Proper maintenance will help to increase the machine's service life considerably.

### 4.3 After the end of the season

The machine must be cleaned, oiled and maintained properly before storage. After the machine has dried we recommend applying a thin layer of oil over the places where the material spread has scratched off the paint.



Ease the tension of the rubber flap when the machine is not in operation.

## 5 Troubleshooting

Problem	Possible fault	Measure applicable
<p>The spreading roller doesn't rotate.</p>	<p>The hydraulic hoses are fitted incorrectly.</p> <p>The flow regulation valve has been adjusted for an insufficient flow capacity.</p> <p>The hydraulic pressure is not sufficient.</p> <p>The material includes stones or large lumps.</p> <p>The chain transfer has broken down.</p>	<p>Switch the position of the hoses; the hose with check-valve must be connected to the return connection of the tractor.</p> <p>Adjust the flow regulator; see Chapter 3.2; Adjustment</p> <p>Check the tractor's hydraulic system.</p> <p>Remove the stones and lumps; use the spreading material with common consistency.</p> <p>Check the machine's transfer from the side.</p>
<p>Poor spreading results</p>	<p>The spreader is not adjusted correctly.</p> <p>Worn rubber flap.</p> <p>Worn plates on spreading roller.</p> <p>Wrong spreading material.</p>	<p>Adjust, see Chapter 3.2; Adjustment</p> <p>Reverse the rubber flap or replace the worn part.</p> <p>Replace the plates or the worn part.</p> <p>Use sand, salt, lime and other materials which do not include large lumps.</p>

## 6 Options

### 6.1 Assembly of Self-loading equipment (optional)

The following parts are necessary to model SP400-SP600-SP800-SP1000-SP1600:

Part no.	Description	Number
320014	Connection frame, 3-P	1 pcs
320015	Link	1 pcs
6-351	Hydraulic cylinder	1 pcs

- Fit the connection frame to the spreader and the link to the connection frame.
- Mount the hydraulic cylinder between the link and the lower middle attachment on the connection frame.
- Connect the arms and the top link of the tractor to the spreader as shown on the picture.
- Adjust the loading angle of the bucket by adjusting the length of the tractors top link.

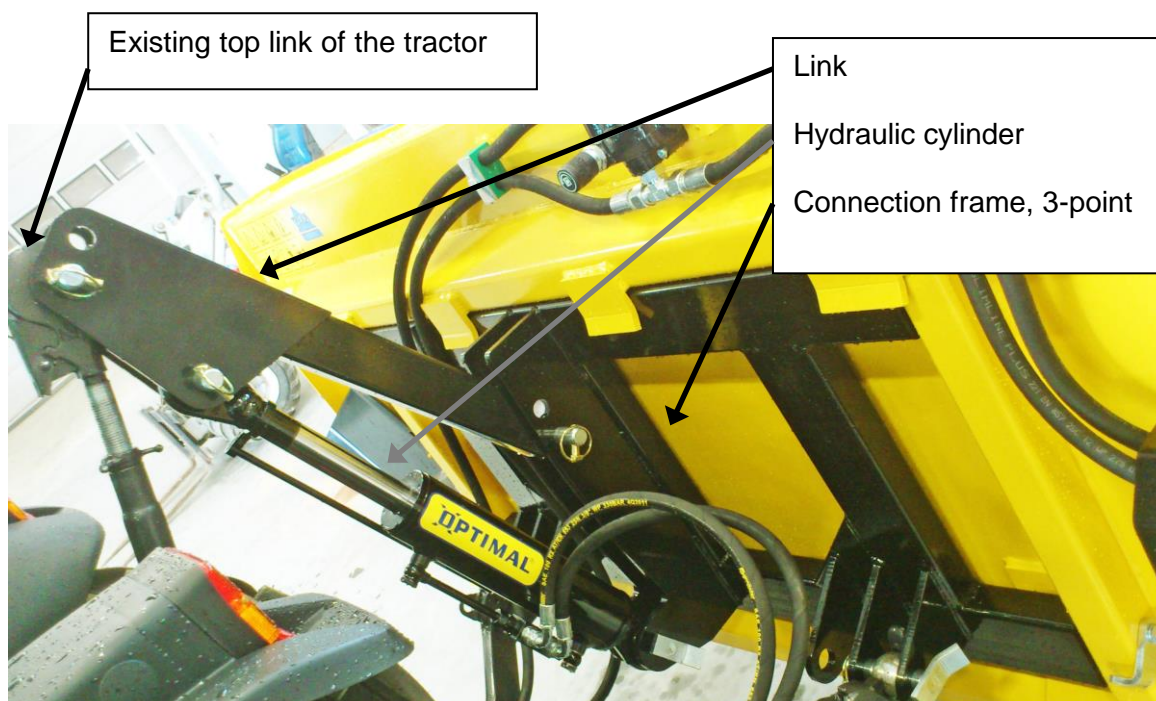

**NOTE! THE LINK IS NORMALLY FITTED AT THE LOWER HOLE OF THE CONNECTION FRAME WHEN USING THE TREJON HYDRAULIC CYLINDER (PART NO. 6-351). THE LINK IS CONNECTED TO CONNECTION FRAME AND TOP LINK IN THE POSITIONS THAT IS MOST SUITABLE FOR THE TRAKTOR. PAY ATTENTION TO THE RISK OF COLLISION WHEN CHOOSING CONNECTION POINTS!!**

### Filling the self-loading bucket

Follow the instructions below to fill the bucket with material stored on ground level

1. Lower the edge of the bucket with the hydraulic cylinder and the hitch of the tractor until the bucket are parallel to the ground. (Picture 1)
2. Reverse the tractor so the bucket cut into the material that is to be filled. (Picture 2)
3. Move slowly forward with the tractor, at the same time raise the edge of the bucket.
4. Continue to raise the bucket with the hydraulic cylinder (Picture 3)
5. Lift up the bucket to a suitable level with the tractor hitch
6. Drive to the place where the material is to be distributed, please also see part 3,3. (Picture 4)

To avoid unnecessary stress on the buckets connection frame and link, we advise you NOT to lift the bucket using the tractor hitch during loading/filling. Use the hydraulic cylinder to raise the bucket, at the same time, move forward from the material.



### 6.2 Curtain cover



Curtain cover is available as option to model SP400, SP600, SP800, SP1000, SP1600 and SP2700.

## Mounting

To fit the curtain cover to the bucket the following tools is needed: power drill, 5 mm steel drill, rivet pliers that handles 5 mm rivets.

- Attach the side of the curtain that lack rubber straps to the front edge of the bucket and cover the opening of the bucket. Attach the curtain over the corners of the bucket.
- The curtain is attached to the bucket by the means of rubber straps and plastic holders, which has to be riveted to the bucket. Please see pictures below.



Plastic holder (1) Rivet 5 mm (2)



Place the plastic holder in the rubber strap and tension the strap towards a surface on the bucket suitable to fit each plastic holder. Mark were the hole should be drilled.



Drill a hole with 5 mm steel drill.

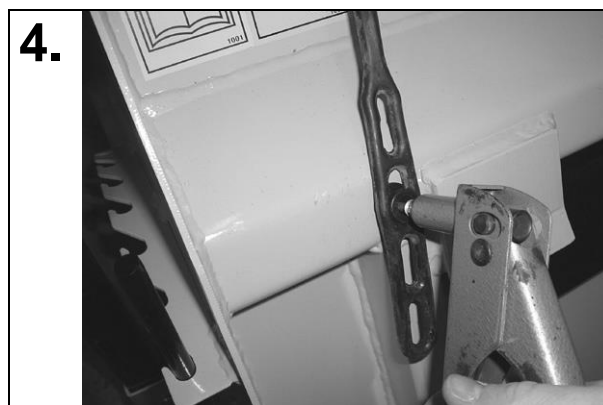

Use a rivet plier to fasten the plastic holder to the bucket.

- Mark, drill and fasten all plastic holders with rivets to the bucket
- Attach the curtain to the bucket

### 6.3 Safety lattice

Safety lattice is available as optional equipment to model SP400, SP600, SP800, SP1000, SP1600 and SP2700.

The safety lattices (1) are bolted to the attachments in the bottom of the bucket by means of bolts and nuts. The lattice is divided in sections that can be folded up for cleaning and mounting of eventual cover plates.

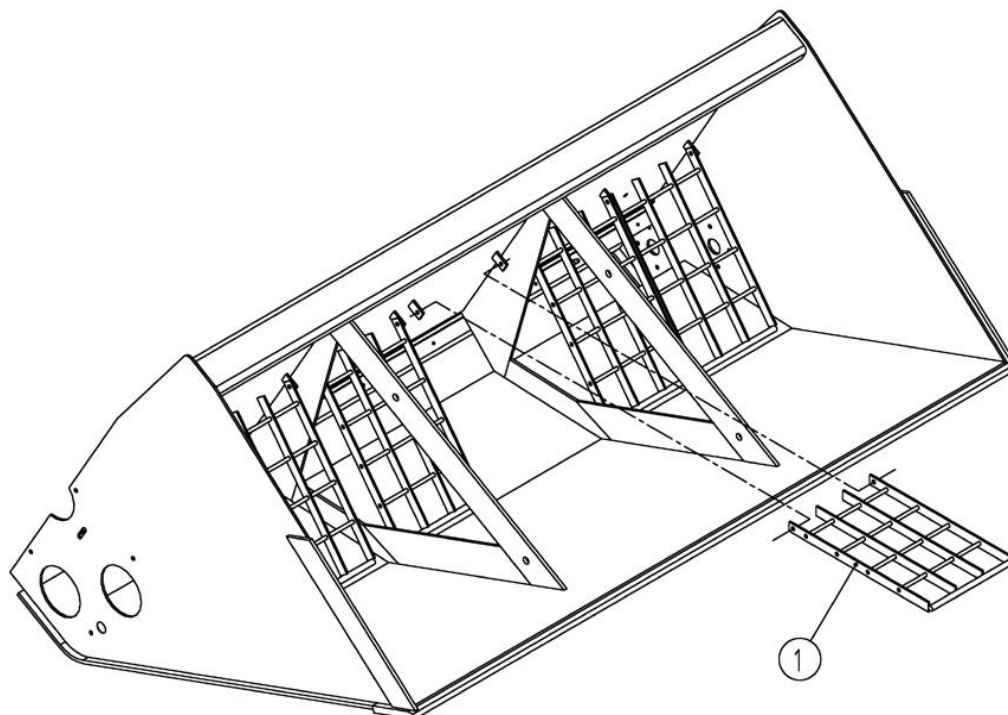

The following parts are necessary to mount the safety lattice to each sand spreader model:

Model	Part no. (complete kit)	Description	Number
SP250	SP-250/21-1	Safety lattice	1
SP400	320233	Safety lattice 21857	2
		Safety lattice 21855	1
SP600	SP-1000-22-1	Safety lattice 21857	2
		Safety lattice 21858	1
		Bolt	6
		Nut, nylock	6
SP800	SP-1000-22-1	Safety lattice 21857	2
		Safety lattice 21858	1
		Bolt	6
		Nut, nylock	6
SP1000	SP-1000-23-1	Safety lattice 21855	2
		Safety lattice 21856	1
		Bolt	6
		Nut, nylock	6
SP1500	SP-1000-24-1	Safety lattice 21857	6
		Bolt	12
		Nut, nylock	12
SP2500	320186		1

## 7 Spare parts

Your choice is between “original” or “copies”!  
Price is often the deciding factor. A “cheap” choice may well be an expensive one in the end.

Some reasons to choose TREJON spare parts:

- Quality and fit.
- Reliability
- Longer service life and therefore better economics
- Guaranteed availability through the TREJON sales partners

The TREJON original spare parts are specifically made for this equipment. The fitting and/or use of non-original parts and accessories may change the technical qualities of your equipment in a negative way. The manufacturer does not give any guarantee for damages caused by using non-original parts or accessories.

The guarantee does not cover arbitrary changes made on the equipment.



If you want to order spare parts or need service, please contact the company where you bought the machine. When submitting the order for the spare parts, specify the model, type and serial number from the name plate on the chassis of the machine.





# EC-Certificate of Conformity

conforming to EEC Directions 2006/42/EG

We **TREJON FÖRSÄLJNING AB**  
(name of supplier).....

**SE – 911 35 Vännäsby, Företagsvägen 9**

.....  
(full address of company – where this concerns authorized agents within the Common Market, also state the company name and manufacturer)

declare in sole responsibility, that the product

Sand spreader SP250	Sand spreader SP400
Sand spreader SP600	Sand spreader SP800
Sand spreader SP1000	Sand spreader SP1600
Sand spreader SP2700	

.....  
(make, model)

to which this certificate applies, conforms to the basic safety and health requirements of EEC Directions 2006/42/EG,  
(if applicable)  
and to the other relevant EEC Directions.

— — —  
.....  
(title and/or number and date of issue of the other EEC Directions)

(if applicable)  
To effect correct application of the safety and health requirements stated in the EEC Directions, the following standards and/or technical specifications were consulted:

**EN ISO 12100-1 : 2010    EN ISO 12100-2 : 2010**

.....  
(title and/or number and date of issue of standards and/or specifications)



**Håkan Johansson**  
Managing Director

**Vännäsby, 01.01.2016**

.....  
(Place and date of issue)

.....  
(Name and job function of authorized person)

## Guarantee- /assignment certificate

- Guarantee terms** - Valid between retailer (Trejon AB dealer) and machine purchaser.
- General about guarantee** - In order to obtain valid guarantee terms set forth below, and the specific guarantee terms set by each provider. These are attached to the user manual for each machine, as appropriate.
- Validity of guarantee** - The guarantee is 12 months from date of purchase.  
In some cases, the guarantee can be limited by running time.
- The guarantee covers** - Damaged parts, which have broken down because of defective production operations of materials in course of normal use of the machine.  
- Only the labor cost for replacement of defective warranted part.
- The guarantee does not cover** - Transport costs applicable to the machine or the parts.  
- Travel costs.  
- Any resulting costs incurred as a result of damage to the machine.  
- If the machine has been modified by the owner.  
- Damage due to normal wear and tear of the machine – Not related to manufacturing defects, poor service, user inexperience or use of spare parts that are not original.  
- Excessive or inappropriate use of the machine.  
- The guarantee is not applicable to parts which are subject to wear, for example hoses, sealing, oil, belts, batteries, chains, knives etc.  
- The guarantee period for replaced parts during the guarantee period expires with the machine's guarantee.  
- Normal adjustments, maintenance or supervision
- Guarantee procedures** - Contact place of purchase as soon as any damage or malfunction is detected. Do not use the machine if the damage can be worse.  
- Guarantee repairs must be performed by Trejon AB approved workshop.

### ATTENTION!

The guarantee shall enter into force provided that the machine **GUARANTEE/ ASSIGNMENT CERTIFICATE** has been fully completed and signed by both parties (archived by the seller), and recorded on the Trejon web portal no later than 14 days from date of sale (the seller is responsible for this happening).

### Assignment certificate:

Machine Buyer shall confirm with his signature that he had received manual containing operating instructions, and received information about the operating, security and maintenance requirements described in this and made the final inspection of the machine.

PLEASE FILL IN!



Product: _____	Serialno. _____
Salesman: _____	Company: _____
Signature of salesman: _____	Date of purchase: _____
Name of buyer: _____	Telephone: _____
E-mail: _____	
Address: _____	Zipcode: _____
City: _____	Country: _____
Date: _____	Signature of buyer: _____



TREJON AB reserves the right to change or to improve shown models using technical or commercial reasons, without demands to carry out the same improvements on equipment already delivered. Pictures in the manual do not necessarily show the equipment as delivered.

Technical data, weights and measures are without obligation. Reservation for faults.

© 2018 Trejon AB, Sweden

Copying, translation and excerpts are only permitted with a written permit from TREJON AB, Företagsvägen 9, SE – 911 35 Vännäsby.

All rights reserved.



**TREJON FÖRSÄLJNINGS AB**

Företagsvägen 9  
SE-911 35 VÄNNÄSBY  
SWEDEN  
Tel: + 46 (0)935 39 900  
Fax: + 46 (0)935 39 919  
Webb: [trejon.se](http://trejon.se)